

PART NAME

NEMA 4 ENCLOSURE

PART No.

AN-1301, AN-1301-G, AN-2801 & AN-2801-B

REV. DATE

12-6-07

MATERIAL: ALUMINUM ALLOY #ADC-12

FINISH: NATURAL (NO SUFFIX)
GRAY (SUFFIX -G)
SMOOTH BLACK (SUFFIX -B)

NOTES:

- 1) FOUR (4) M4 x 20mm (0.787") LG. SCREWS SUPPLIED FOR ASSEMBLY OF COVER TO BODY.
- 2) ALL HOLE DIAMETERS HAVE ±0.005 TOLERANCE
ALL OTHER DIMENSIONS HAVE ±0.015 TOLERANCE

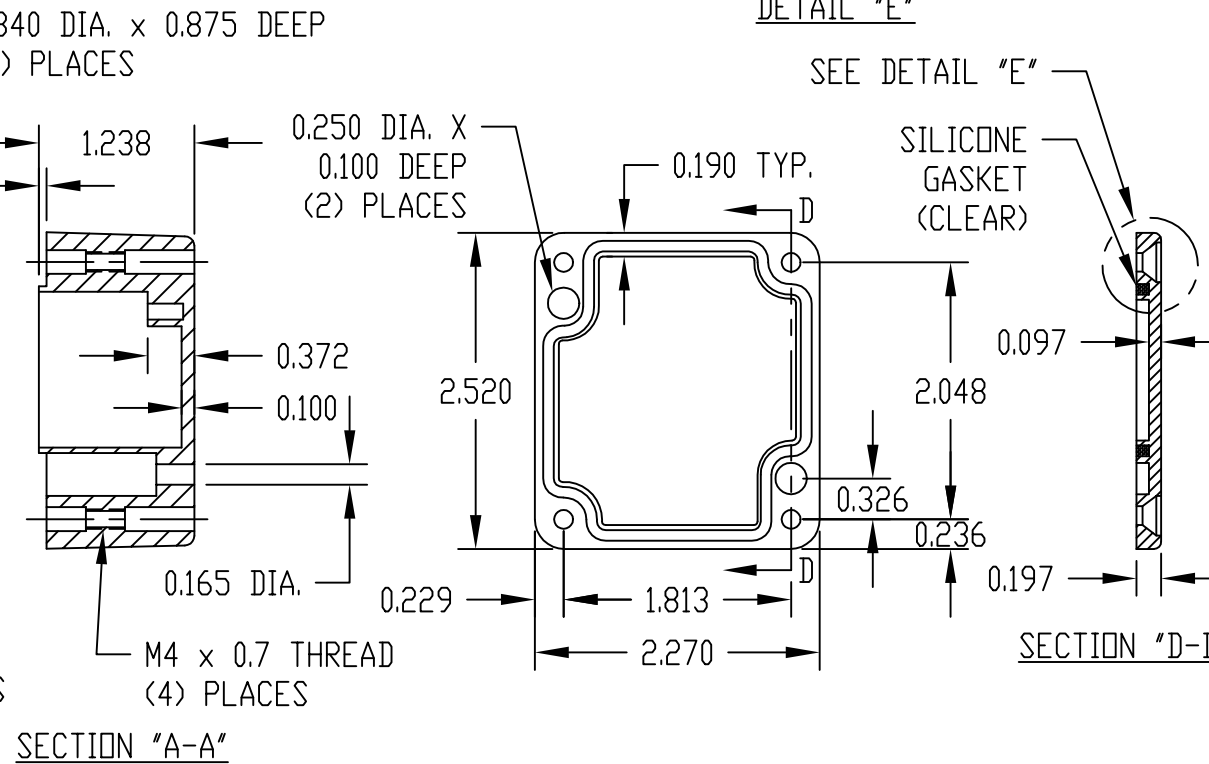
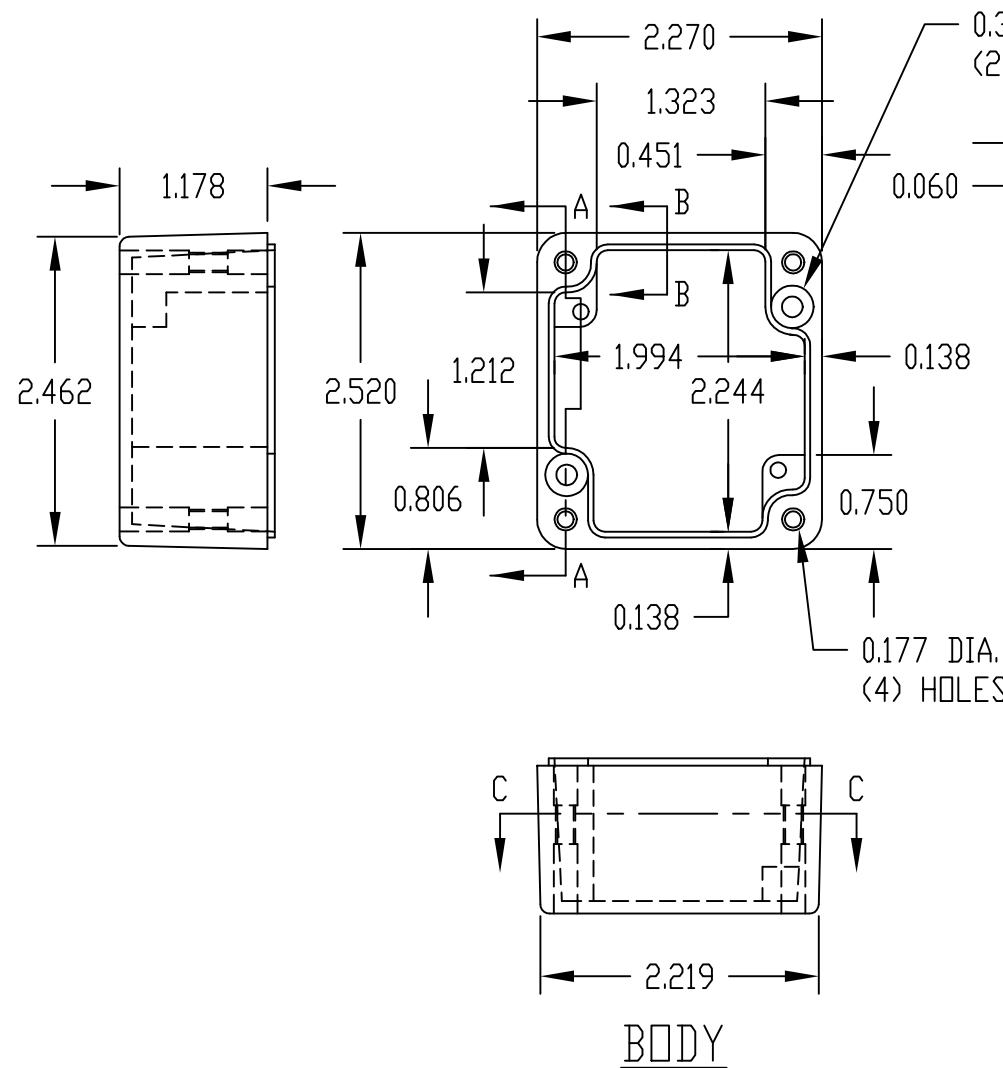
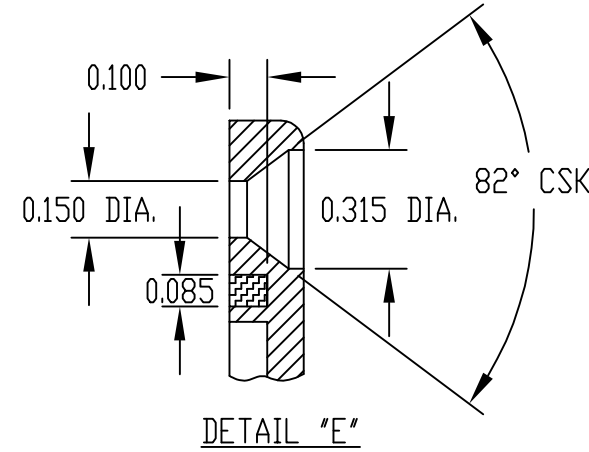
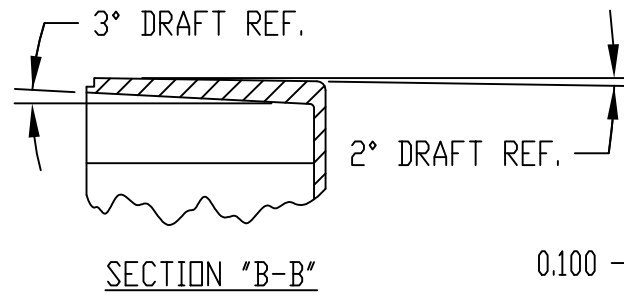
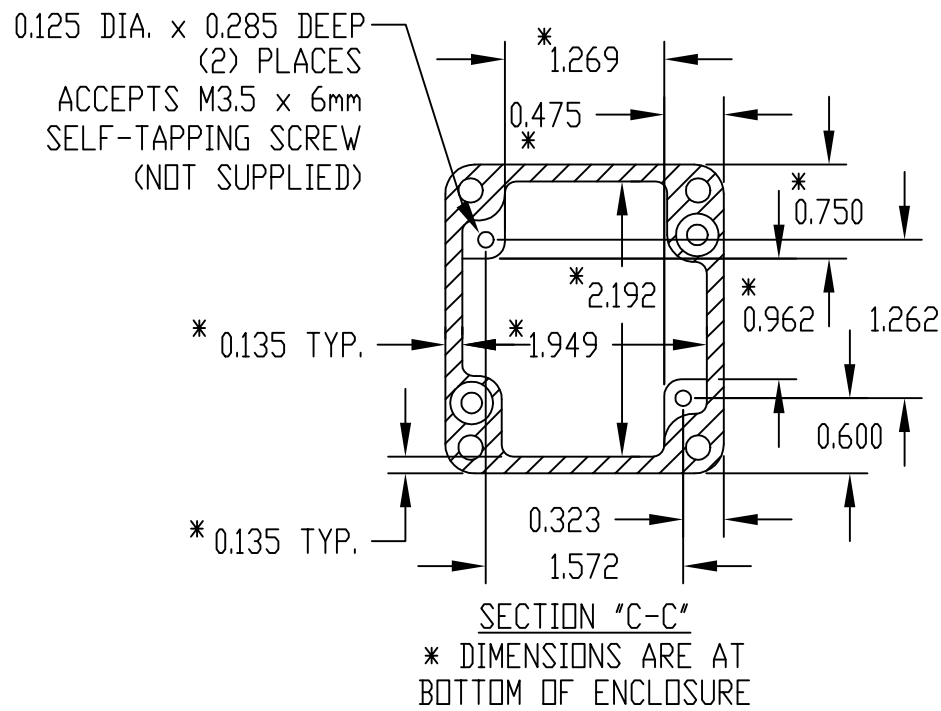

COVER

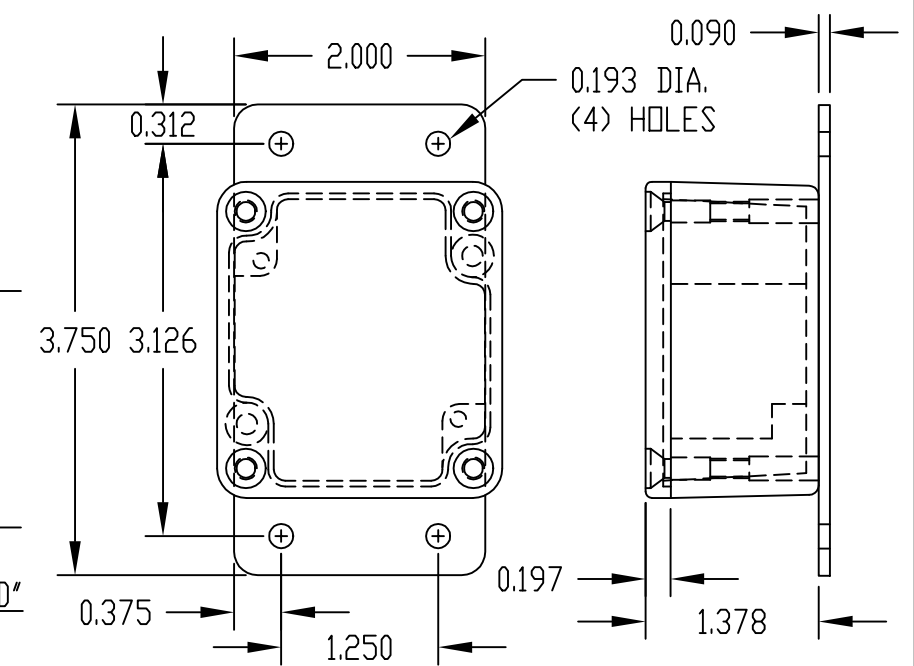

PART NO. AN-2801 & AN-2801-B ARE SUPPLIED WITH A WELDED ON MOUNTING BRACKET ONLY.